

IMPORTANT! PLEASE READ BEFORE HANDLING YOUR AIR RIFLE

Remington®

TYRANT™

AIR RIFLE OWNER'S MANUAL



IMPORTANT!

This manual contains operating, care and maintenance instructions. To assure safe operation, any user of this airgun must read and understand this manual before using the airgun. Failure to follow the instructions and heed the warnings in this manual can cause property damage, personal injury, and/or death.

This manual should always accompany this airgun, and be transferred with it upon change of ownership.

AIRGUN PELLETS



WARNING: This airgun is not a toy. This airgun is designated for use by experienced adult shooters, ages 18 and older. This airgun is intended for match, competition and/or range shooting. Misuse or careless handling of the airgun may result in property damage, personal injury and/or death.

KEY FACTS: The Tyrant™ Air Rifles (i) are MANUFACTURED IN CHINA for Remington Arms Company, LLC, 870 Remington Drive, Madison, North Carolina 27025; (ii) is design to only shoot .177 AIRGUN PELLETS; (iii) shoots projectiles for .177 at velocities up to 1000 feet per second; when used with the recommended ammunition and in accordance with the enclosed operating instructions.



WARNING: This product uses Lead Pellets, a chemical known to the State of California to cause cancer and birth defects (or other reproductive harm). Do not inhale lead dust or put Lead Pellets in your mouth. Wash your hands after handling. Keep away from children.

Tyrant™ (.177)		THE LEAD VELOCITY AND MAXIMUM DISTANCE ARE DEPENDANT ON THE WEIGHT OF THE PELLET USED WHEN CALCULATING THESE FIGURES. LEAD PELLETS WERE USED IN THIS CALCULATION.
LEAD VELOCITY	1000 fps	
MAX. DISTANCE	600 yds (549 m)	

Tyrant™ (.177)	
ALLOY VELOCITY	1200 fps

Ten Rules of Airgun Safety:

1. Always keep the muzzle pointed in a safe direction.
2. Airguns should be unloaded when not in use.
3. Don't rely on your airgun's safety.
4. Be sure of your target and what's beyond it.
5. Use proper projectiles and propellants.
6. If your airgun fails to fire, handle with care.
7. Always wear eye and ear protection when shooting.
8. Be sure the barrel is clear of obstructions.
9. Don't alter or modify your airgun.
10. Learn the mechanics and handling characteristics of your airgun.

 **WARNING:** This airgun is classified as an adult gun and is recommended for adult use only. This airgun is exempt from specific types of trigger pull, safety mechanisms and drop test requirements. This airgun may discharge if dropped. Misuse or careless handling of the airgun may result in property damage, personal injury and/or death.

 **WARNING:** Use of improper projectiles may cause property damage, personal injury and/or death.

 **WARNING:** Reuse of projectiles may cause property damage, personal injury and/or death.

 **WARNING:** Modification of the airgun mechanism may cause a airgun to malfunction and tampering with an airgun may make it unsafe to use and cause property damage, personal injury and/or death.

 **WARNING:** Do not brandish or display an airgun in public. Police and others may mistake the airgun for a firearm. Public display of an airgun may break local laws and/or regulations.

 **WARNING:** Do not change the coloration and marking of this airgun to make it look more like a firearm. Altering the aesthetics of an airgun to be more firearm like may break local laws and/or regulations.

 **WARNING:** If the performance of your airgun changes, have it inspected and repaired by an authorized repair center. Use of an airgun in need of repair may cause property damage, personal injury and/or death.

 **WARNING:** All repairs to your airgun should be made by an authorized repair center. Improper repairs and/or maintenance of an airgun may cause property damage, personal injury and/or death.

 **WARNING:** Inspect your airgun for proper function after each use, and if the airgun has been dropped or abused in any manner. Use of an airgun in need of repair and/or maintenance of an airgun may cause property damage, personal injury and/or death.

Contents of this Manual

4. How to Cock your Airgun
Proper Use of the Safety
5. Loading your Airgun
6. How to Check the Barrel for Obstructions
How to Remove a Barrel Obstructions
7. Shooting your Airgun Safely
8. Sight Picture, Aperture Sight & Telescopic Sight
9. The Trigger and Typical Spring Piston Mechanism
10. Troubleshooting
12. Which Pellets To Use? and Basic Points
13. Parts List
14. Parts Diagram
16. Special terminology
16. Warranty Information
17. Warranty Certificate

Statement of Non-Liability

Remington. assumes no liability for this airgun's resale, handling, use or possession under local laws or regulations. Remington. will honor no claims that may result from careless handling, unauthorized adjustments, defective or improper ammunition, corrosion or neglect.

The Remington® Tyrant™ break barrel air rifles are easy to operate, consistent, and can provide trouble free use if the provided instructions are adhered to. A few minutes spent reading this manual are essential to safe operation and will increase the many years of pleasure you will derive from this fine airgun.

BASIC NOMENCLATURE: A typical “barrel-cocking” air rifle is shown below. The basic internal parts are shown on page 9.

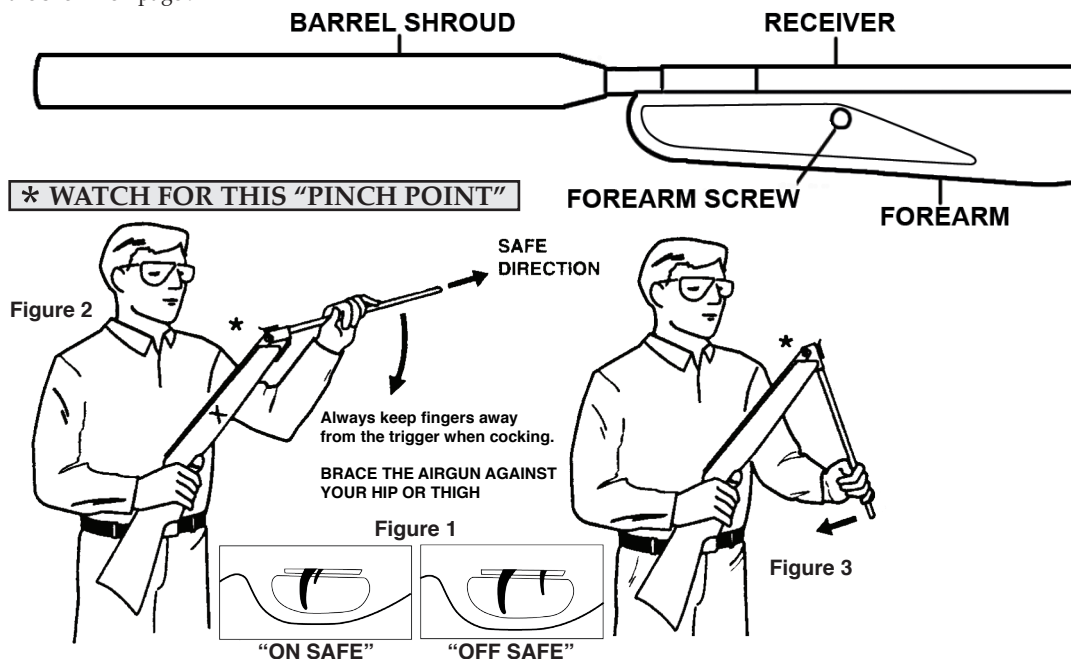

How to Cock your Airgun

Your airgun is powered by a powerful spring in the receiver. Follow all procedures for safe handling.

1. Always keep the airgun pointed in a safe direction.
2. With one finger pull the safety towards the trigger into the "ON SAFE" position. See Figure 1.
3. With one hand, hold the stock at the pistol grip or middle of the forearm (marked by X). Holding the air rifle firmly, tap middle of barrel behind the front sight in order to break the locked position. See Figure 2.
4. Grasping the barrel, smoothly pull the barrel downward until you hear a loud click -- this indicates that the air rifle is cocked and the internal automatic safety is engaged. See Figure 3.
5. Be sure to keep control of the barrel under strong pressure until the audible click is heard.
6. Be careful not to pinch your hand or fingers in the hinged area.

7. Now, **WITHOUT TOUCHING THE TRIGGER OR SAFETY**, pull the **barrel** fully upward, completing the cocking action. You will feel it and when the piston clicks into the cocking position and the internal automatic safety is now disengaged. See Figure 4.

This airgun is equipped with manual safety, be sure that it is in the "SAFE" position before the airgun is cocked. Do not pull past this point and never use excessive force or speed.

Proper Use of the Safety

This airgun is equipped with manual trigger safety, with an internal automatic safety feature which prevents the piston from releasing while the barrel is open for loading. Engage the safety by pulling it towards the trigger and to disengage the safety pushing the lever forward towards to barrel.

NOTE: Pulling the trigger of this airgun when the barrel is in the downward cocked position, with the safety in the "Fire" position, will "catapult" the barrel to the closed position with great force. Causing the airgun's barrel to "catapult" is considered abuse and is not covered by any warranty, repair policy and/or service contract.

These features reflect the more sophisticated requirements of precision adult airgun shooting. These non-powder guns are intended for use by experienced adult shooters who understand their proper and safe use.

WARNING! Keep your hands and other objects away from the trigger and safety during the cocking and loading procedure. An uncontrolled discharge of an airgun can cause property damage, personal injury and/or death.

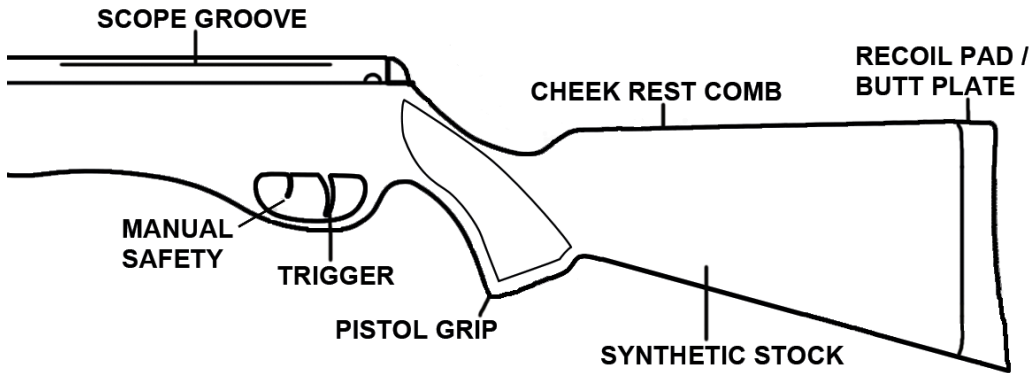

Figure 7

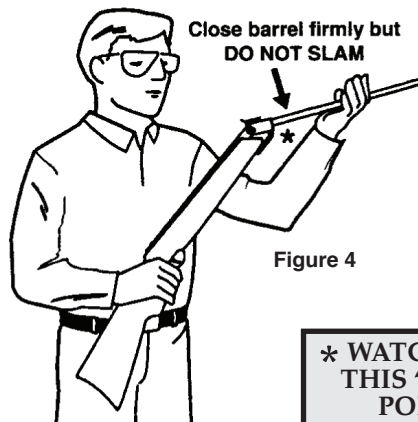
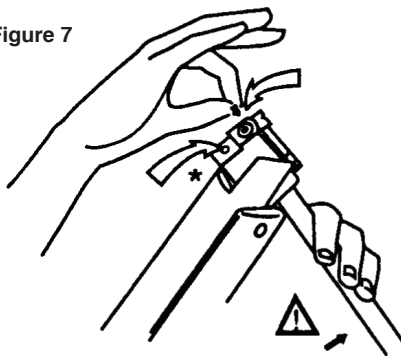

Figure 4

*** WATCH FOR THIS "PINCH POINT"**

Loading the Airgun

Airgun pellets are loaded and shot one at a time. Be sure to use airgun pellets of the correct caliber for your airgun.

1. Always keep the airgun pointed in a safe direction.
2. With one finger push the safety towards the trigger into the "ON SAFE" position and open the barrel in to the cocked position, visually verify the barrel if free of obstructions. See "To Check the Barrel of Obstructions" section of this manual.
3. Place the solid end of the pellet directly into the barrel's chamber. See Figure 7.

4. Push the pellet into the barrel chamber, until the skirt of the pellet (open end) is flush with the edge of the chamber.
5. Lock the barrel closed by rotating it upward until you hear the locking mechanism click.
6. Verify the safety is in the "ON SAFE" position. See Figure 1. If the safety is in the "OFF SAFE" position, conduct steps 1 through 7 of the "How to Cock your Airgun" section of this manual.

NOTE: Closing the barrel forcefully can damage the airgun and is considered abuse and misuse. Abuse and misuse of the airgun is not covered by warranty of this airgun.

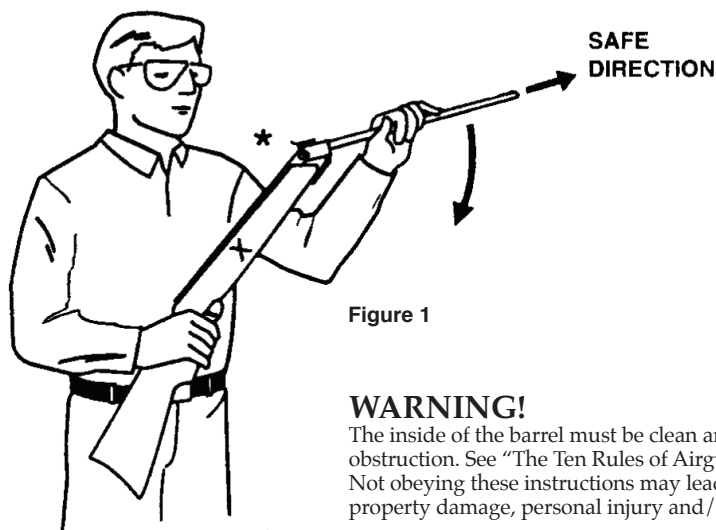

Figure 1

WARNING!

The inside of the barrel must be clean and free of obstruction. See "The Ten Rules of Airgun Safety." Not obeying these instructions may lead to property damage, personal injury and/or death.

How to Check the Barrel for Obstructions:

1. Always keep the airgun pointed in a safe direction.
2. With one finger pull the safety towards the trigger into the "ON SAFE" position.
3. With one hand, hold the stock at the pistol grip or middle of forearm (marked x in the Figure 1).
4. Holding the airgun firmly with one hand, tap barrel behind the front sight in order to break open the barrel, but do not cock the airgun. See Figure 1.
5. Align your eye with the axis of the barrel and look into the barrel's chamber.
6. Visually verify the barrel is free of obstructions.
7. Physically verify the barrel is free of obstructions by inserting a cleaning rod of the correct size into the chamber.
8. Push the rod completely through the barrel, until the rod can be seen protruding from the barrel's muzzle.

How to Remove a Barrel Obstructions:

1. Insert the cleaning rod into the barrel's chamber and lightly tap the rod to free the object the barrel.
2. Push the rod all the way though the barrel until the rod can be seen at the barrel's muzzle.
3. If an object cannot be easily pushed out of the barrel with the cleaning rod, return the airgun to a Remington Authorized Repair Center.

If you have cocked your air rifle, loaded a pellet and decided not to take the shot in a reasonable amount of time, do not leave your airgun cocked.

- A. If already loaded: Removing the pellet is inadvisable and doing this with a sharp object could seriously damage the delicate rifling. The best course of action is to shoot the airgun into soft ground, a pellet trap or thick pile of newspapers or magazines.
- B. If unloaded: BE SURE AIRGUN IS UNLOADED. * Then put muzzle tightly against firm, soft pad (such as padded rug - but NEVER against part of your body), to provide air resistance, and discharge airgun. Try not to do this often. A better way is to load a pellet and discharge the airgun safely in the regular way.

**Always check an airgun to see if it is loaded when removed from storage or received from another person. The ONLY ways to be sure that your barrel is unloaded is too look through the bore from the rear or pass a cleaning rod through the bore from the rear.*

Shooting your Airgun Safely

NEVER SHOOT A SPRING PISTON AIRGUN WITHOUT A PELLET!

To do so permits the piston to slam hard against the front of the compression chamber. Repeated "dry firing" can damage your airgun.

It needs the cushioning action of the air compressing behind a properly fitting pellet to work correctly. Also, for this reason, you should not shoot damaged or previously fired pellets. Steel BB's and darts, low quality or irregular pellets can damage your airgun and should not be used. Any other unauthorized projectiles are not recommended.

Shoot your airgun shortly after cocking and loading. Do not leave the airgun cocked for extended periods of time.

1. Always keep the muzzle pointed in a safe direction.
2. Verify the barrel if free of obstructions. See "To Check the Barrel of Obstructions" section of this manual.
3. Load the airgun. See "Loading your Airgun" section of this manual.
4. Point the muzzle at your intended target.
5. Disengage the safety mechanism by moving the safety to the "OFF SAFE" position.
6. Acquire the target.
7. Discharge the airgun by pulling the trigger when ready.
8. Break open the action. See Figure 1.
9. Look into the chamber and visually check to see the barrel is empty.

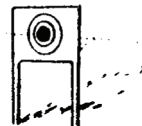

Always be sure of your back stop. Be sure that the entire path of your pellet, even beyond the target, is safe! Do not shoot at glass or hard surfaces. Avoid ricochets. It is impossible to predict where a glancing shot will fall. Remember a pellet may travel up to about 600 yards (549 meters).



Shooting glasses are a must for all airgun shooters and spectators.

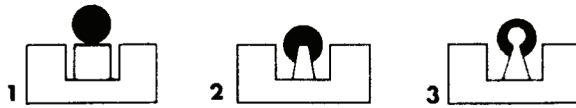

Sight Picture

What you see when you are aiming at a target is called the "Sight Picture." For accurate shooting this relationship of sights and target must be correct and above all consistent from shot to shot.

The open sight: The front sight is usually either a post or a post with a "bead". The open rear sight is usually attached just in front of the breech. It has a "U" or "V" notch. Some airguns give you an assortment of rear notches. There are three correct sight pictures.

1 the "6 o' clock" hold is best for target shooting since it gives a clear cut reference point. The post is centered in the rear notch with the top of the posts level with the top of the notch.

Maintaining this relationship, place the post just under the "bullseye" so that the bullseye appears to be sitting right on top of, or above the post. The sights are adjusted so the pellets strike above this point in the center of the target.

2 The "point of aim" hold is considered the best for field use. The relationship of front and rear sights are set so pellets strike exactly where the sights point at the distance the airgun is "sighted in."

3 If your air rifle has a "bead" front sight, this is the correct sight picture. With a bead front, the "Point of Aim" hold is best.



Aperture Sight

Some air rifles are equipped with an aperture sight (also known as receiver, peep, or diopter sight). It may be purchased as an option for some air rifles. This is a very easy sight to use and it is far more accurate and faster than an open sight because there is less guess work in its use and the distance between front and rear sight ("sight span") is much greater. To use an aperture sight, just look through the aperture or "peep", find the front sight, and put the front sight on the target. When looking through the receiver sight try to

ignore the aperture, do not try to "center" the front sight. The human eye cannot focus on three objects so far apart. The eye will automatically seek the strongest source of light coming through the aperture and this automatically centers the front sight. If you should install an aperture sight on an air rifle that has an open sight already on it, remove the rear sight after lining up the receiver sight with it (Aperture sights are not suitable for air pistols). NOTE: Most air rifles will require a barrel angle correction before installing an aperture sight.

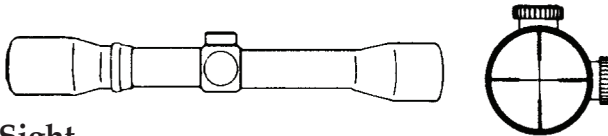

Telescopic Sight

This is the simplest and fastest to use of all since it has magnification and only one plane of focus. Also many scopes actually gather light or allow shooting when it would be too dark for iron sights. Put the crosshairs on your target and shoot. Adjust as per scope instructions. NOTE: Be sure that the scope that you put on your airgun is designed specifically for airgun use.

Most scope for firearms are parallax adjusted to 50 meters, where as airgun scopes are parallax adjusted to 10 meters. The scope must be factory adjusted for correct airgun range or have a properly set adjustable "Range Focus" dial at the front end of the scope tube or you will shoot inaccurately, as much as half-inch off at 25 yards (12mm at 23m).

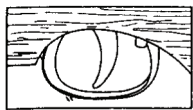

The Trigger

The majority of adult spring piston airguns have what is known as a “two stage”

trigger. The first “stage” is merely a predetermined amount of take-up or slack preparatory to the last or “second stage” which is the let-off or actual firing stage. This is a European custom and is designed to aid the shooter to embrace and steady for the discharge of the rifle.

The trigger pull setting as it comes from the manufacturer is usually the best for the airgun in question and should not be lightened. A good trigger pull for an adult airgun is about 3-6 pounds (1300-2700 gms).

Trigger technique: Assume a normal standing or rest position, take a correct sight picture. Now take a normal breath, hold it, and then squeeze the trigger. Do not jerk or slap the trigger. There is no substitute for practice. Happily, with an adult airgun practice is easy and inexpensive. For details, consult a recommended book on match shooting techniques.



WARNING! Modifications and/or tampering with a trigger mechanism may cause an airgun to malfunction and become unsafe to use.



CAUTION: do not use oils or solvents intended for firearms or other devices in the compression chamber of any spring piston airgun! to do so can cause severe detonation or “dieseling effect,” resulting in possible damage to airgun and injury to the shooter and/or bystanders.

Only special lubricants specifically designed for spring piston airgun compression chambers should be used. These are sophisticated silicone oils specially formulated for the purpose. Of the hundreds of silicone oils available, only a few have the proper flash point, viscosity, lubricity, lack of acids, etc., for use in the fine quality spring piston airguns. Incorrect lubes can be dangerous.

The reason for this is that during the firing cycle of a spring piston airgun compressed to quite high pressures, resulting in high temperatures for a fraction of a second. This heat can actually explode any vaporized flammable oils in the chamber. Very light dieseling is often experienced with a new airgun that has not been “broken-in”.

The manufacturer oils and lubricants can cause minor dieseling. The airgun may make a loud “crack” and give off some smoke. Usually this stops after a few dozen shots and the airgun settles down to its normal pressures. Sometimes it may take a tin or two of pellets before the excess lubricants are cleared. A wisp of mist or smoke after shooting is not cause for alarm and is a sign that your airgun is getting some vapor lubrication into the barrel, a good thing.

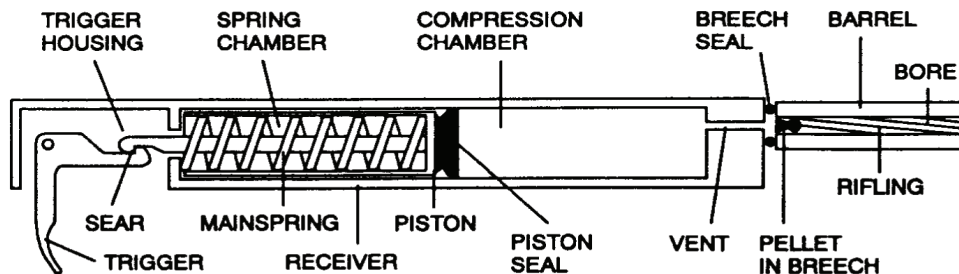

Typical Spring Piston Mechanism

Note: This diagram has been simplified for clarity, the airgun is shown in the cocked position. In a Gas spring airgun the “mainspring” consists of a sealed unit of compressed gas.

Troubleshooting

NOTE: Spring piston adult airguns have characteristics which are unique. Most “problems” encountered by new owners are often really not problems at all or are easily corrected. In any case, most experts agree that the spring piston system is the most trouble free of all airguns power mechanisms.

PROBLEM: POOR ACCURACY/Possible Causes:

1. Dirty bore. Most accuracy complaints are traced to an unclean bore. Even a barrel which appears to be clean may be shooting well below its potential. Look up the bore from the breech (directly or with a small mirror). If you don't see shiny clean rifling the bore is dirty. **SOLUTION:** Felt cleaning pellets are ideal for this purpose - and are easy and fast to use. (See bore cleaning in the basic points section overleaf.)

2. Not Using Special Shooting Techniques. Because of the relatively long time that pellets remain in the airgun after the trigger is pulled, as compared to bullets in a firearm, airguns are much more sensitive to shooter motion. This is one of the reasons why airguns are so good for teaching technique to firearm shooters. Many excellent firearm marksman do NOT do well with airguns until they have improved techniques that were not so critical with firearms. Published accuracy figures were obtained by AIRGUN experts under ideal conditions. Imperfect techniques, especially some techniques which are excellent for firearms, may cause oversize groups. **SOLUTION:** Give yourself time to become accustomed to each airgun. Do not rest barrel on anything while shooting. Using sandbags or firearms bench rest methods often will give you very poor accuracy with airguns. Use loose consistent pressure and replace airgun to same, position for each shot.

3. Minor dieseling often occurs in new airguns. This is the burning off of manufacturing oils and greases. The airgun “cracks” and shots go high or wild due to higher velocity. **SOLUTION:** This problem usually solves itself after a few shots. Some airguns may require 500 to 1,000 pellets or even internal “super tune-up”, to be completely “cured”. Over lubrication, or improper lubrication, is a very common cause of this and several other airguns problems.

4. Loose stock screws. This is a major cause of inaccuracy in airguns new or old. One quarter of a turn may affect accuracy by 2 inches (50mm). **SOLUTION:** Tighten front and rear screws very firmly. If problem recurs, remove screws, degrease screws and screw holes thoroughly and apply Loc-Tite 242 sealant.

5. Incorrect or defective pellets: Keep in mind that each air rifle is unique and it requires some experimentation on your part to find just exactly the types of pellets that will work best for each of your particular airguns. Damaged pellets will not shoot well and may damage the airgun.

6. Breech seal leak. The breech seal may be defective, worn from use or damaged due to dieseling. **TEST:** Cock and load the airgun. Hold the palm of your hand about 1/2” (15mm) above the joint between the breech and receiver. Be very careful not to let this hand touch the airgun. If there is a seal leak you will feel a strong blast of air, a slight leak is normal blowoff of excess pressure in many models. **SOLUTION:** Replace seal. A severe leak can cause a piston to slam into the end of the chamber with eventual piston, spring and chamber damage. (Don't disturb even an ugly, blemished seal if it works well!)

7. Improper pellet seating. Correctly seated pellets have the pellet skirt flush with, or below, the face of the breech. In top loading airguns, the pellets often drop a short distance into the barrel or top - this is correct. Improper pellet seating may cause the pellet skirt to become smashed when breech is closed. **SOLUTION:** Seat pellets deep enough, carefully and consistently.

8. Bent or weakened mainspring. Mainsprings can assume a “set”, become bent, or even break. Metal fatigue can cause a spring to lose some of its elasticity. Years of use or leaving your airgun cocked overnight can cause low velocities. If an airgun becomes hard to cock or velocity decreases this is a good indication of a broken and/or weakened mainspring. **SOLUTION:** Have mainspring replaced by a technician.

9. Loose sight. Front and/or rear sight screws or scope mount screws can work loose. **SOLUTION:** Tighten all sight and scope mount screws firmly with correctly fitting gunsmith screwdrivers. If problem continues, remove sights or scope mount and degrease all mating surfaces thoroughly three times, apply film of Loc-Tite 242 (Use standard, not industrial Loc-Tite 242) to sight/airgun contact points and reinstall, tightening screws well.

**PROBLEM: AIRGUN DOES NOT SHOOT/
Possible Causes:**

1. Shooter Error. Shooter may not be cocking airgun to full cock. **SOLUTION:** Bring barrel (or cocking lever) all the way back until it stops and gradually increase pressure until a final “click” is felt. **DO NOT** force.

2. Broken mainspring. CAUTION: Repairing airguns should only be attempted by a technician. Personal injury and/or airgun damage is possible if this is incorrectly done. **NOTE:** Repairs and /or enhancements performed by a non-technician will void your warranty, service contract and /or repair policy!

3. Safety in “on” position. Always check safety before firing trigger. Some airguns have an automatic safety, in others the safety may have been manually engaged. **SOLUTION:** Put safety in “fire” position manually. Always point airgun in safe direction before releasing energy.

**PROBLEM: ACCIDENTAL DISCHARGE/
Possible Causes:**

1. Airgun not fully cocked. Due to hasty cocking. **SOLUTION:** Be sure to cock deliberately. Excessive force is never necessary.

2. Trigger setting too light. This a dangerous situation. Most commonly due to owner over “improving” trigger pull. **SOLUTION:** Increase trigger pull weight setting.

**PROBLEM: PELLET FIT VERY TIGHT/
Possible Causes:**

Some airguns are engineered with a tight breech for maximum performance. Such airguns depend on the pellet holding still, like a cork, until the air pressure reaches a critical peak.

**PROBLEM: STOCK BREAKS OR CRACKS/
Possible Causes:**

This is always caused by dropping the airgun or allowing the barrel to snap shut to itself (This also causes cocking levers and barrels to bend!) This is not covered by repair policy, warranty or service contract.

Due to variations, between the country of origin and final area where stock is used, minor drying cracks (called checks) may appear. They are superficial blemishes and almost never enlarge. All new airguns have some small blemishes; those selected for stock condition have fewer such blemishes, but no stock is perfect.

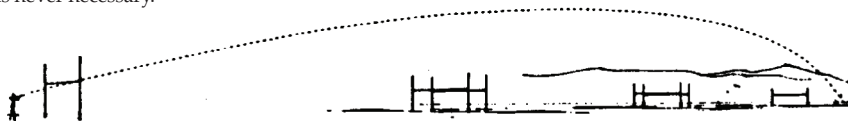

WARNING! the airguns described here are designated as Match Precision or Adult Airguns and, as such, are exempt from having a “safety” may have trigger pulls below 2 lbs. (900 gms) and may fire when dropped.

Important Safety Tips In addition to the instructions and cautions on the preceding pages, we would like to include a few basic tips for your safe shooting practices. Some points are important enough to repeat!

- **Normal operating temperature of piston airguns is approximately 20° to 110°F (-6° to 42°C).**
- **Always check to see if the airgun is loaded** when removed from storage or received from another person! A pellet may be in the bore without being easily visible! See clearing bore instructions. Never fire, even unloaded, airguns against any part of your body.
- **Never allow anyone, especially youth, to use an airgun loaded or unloaded until they are fully trained in airgun safety and proper use!**
- **Treat all airguns as if loaded.** Follow safe airgun handling practices. Remember that airguns can be dangerous if mishandled. Precision adult airguns are not toys; they can cause serious injury or even death. For proper training and information contact your local airgun clubs and/or the National Rifle Association.
- **Adjustments and repairs** should be made only by technicians. Never use a malfunctioning airgun!
- **Store the airgun in safe and proper place,** secure from unauthorized use. Locking it up is best.
- **Shoot safely:** Airgun pellets may travel up to 600 yards (549 meters). Be sure of your backstop. Avoid ricochets. Do not shoot at hard surfaces. Shooters and bystanders should always wear shooting glasses during firing. **NEVER** depend on a “safety”.

Which Pellets To Use?

The all important ingredient to airgun shooting success:

You need several different kinds.

Airgun pellets, just like firearm ammunition, are available in a great variety of weights and shapes to suit particular shooting needs. The following will help you select the type of pellets that will work best for you. Keep in mind that each air rifle and air pistol is an individual and it requires some experimentation on your part to find just exactly the types of pellets that will work best for each of your particular airguns.

The quality of the pellets that you shoot in your airguns will determine the success you have on the target range or in the field. It is essential to shoot only

high quality pellets in spring-piston airguns. Low quality or deformed pellets not only result in poor accuracy but can actually damage these airguns by allowing compressed air to blow by the pellet and cause the piston to slam harshly against the forward end of the compression chamber.

Always use proper pellets. Use only high quality pellets to avoid harmful oils, abrasive material and airgun wrenching air blow-by. Precision adult airguns are intended for use only with precision airgun pellets; steel shot or darts are not recommended and generally damage rifled bores and may cause dangerous ricochet or rebound. Properly seated pellets should not show rub marks on rear of skirt when breech is reopened prior to firing. Damaged, used, or unauthorized projectiles may be unsafe.

BASIC POINTS:

The **COMPRESSION CHAMBER** is that portion of the receiver where the actual air compression takes place when the piston moves forward in shooting, since the air is heated to as high as 2,000°F for a fraction of a second upon firing, excessive lubrication will cause dieseling (detonation) that can possibly damage the airgun and injure the shooter. Lubrication should be performed by technicians during regular service intervals.

MAINSPRINGS are the storehouses of the energy the shooter provides by cocking the airgun, and need to expand smoothly with as little friction and vibration as possible. The mainspring is housed in the spring cylinder, which is a polished cylinder containing the piston, the mainspring, and the spring guide shaft. All metal mainsprings eventually have some cant; therefore, the polish and lubrication of all surfaces here is critical for maximum performance. Recoilless airguns receiving extensive use in competition should be serviced once a year by technicians.

COCKING LEVER LINKAGES receive considerable pressure; proper lubrication insures smooth operation and minimum wear. Moly is also useful in such areas as the sliding parts.

BARREL PIVOT POINTS and detents benefit from lubrication. Remember, do not over lube, and keep low flash point oils away from air vent and breech seal.

Front and rear **STOCK SCREWS** must be firmly tightened and checked before each use of your air rifle. If loosening occurs, remove stock screws, degrease stock screws and stock screw holes thoroughly; then sparingly apply Loc-Tite 242 (blue) sealant, and tighten firmly.



































BORE CLEANING. Since airguns do not use powder or primers, cleaning is not necessary to prevent most rust; however, it is essential to good accuracy. Accuracy suffers badly due to caked grease residues blown into the bore from the compression chamber and from leading. Most accuracy complaints are the result of dirty bores-even though they may look clean! For storage, clean the bore and leave it with a light coating of CLP (Cleaner, Lubricant, Protectant) oil. After cleaning with CLP oil (do NOT use regular firearm bored cleaners as they will damage seals and cause dieseling), follow with dry patches until no trace of oil is seen. A few regular pellets will have to be shot through a cleaned barrel before it can be expected to return to its "zero".

EXTERIOR SURFACE should be regularly wiped with a silicone cloth to maintain the quality of the finish. Before airguns are stored, they should be given a good wiping with a very high-grade polarizing oil.

USE PROPER PELLETS! Use only high quality pellets to avoid harmful oils, abrasive material and airgun barrel damage. Precision adult airguns are intended for use only with lead, or non-lead alloy pellets. Steel shot or darts damage air rifle bores. Properly seated pellets should not show rub marks on rear of skirt if breech is reopened prior to firing. Damaged, used or unauthorized projectiles may cause dangerous ricochet, excessive piston impact and excessive penetration.

ACCURACY TESTING. The accuracy of the airgun will only become constant once barrel and cylinder are fully bedded in. This usually takes approximately 1000 - 1500 shots, this applies to open sights or being used with telescopic sights. High constant accuracy can only be achieved if the rifle is correctly zeroed in with an appropriate scope and mount system and shot from a bench rested position.

PART LIST

1		Piston Seal	19		Link Pin
2		Piston	20		Break Bolt
3		Front Spring Guide	21		Washer
4		Piston Spring	22		Bushing
5		Back Spring Guide	23		Lever Assembly
6		Spring Guide Assembly	24		Plain Washers
7		Tube Cover	25		Pan Head Screws
8		Front Sight Not included	26		Bear Trap Lever
9		Barrel Shroud	27		Safety Spring
10		Rear Sight Not included	28		E-ring
11		Adjust Washer	29		Trigger Pack Assembly
12		Breach Seal	30		Stock Link Bolt
13		Jam Spring	31		Stock Lug Brace
14		Alive Jam	32		Stock Assembly
15		Detent	33		Trigger Guard
16		Compression Tube Assembly	34		Screw, Trigger Guard Front
17		Fixed Pin	35		Screw, Trigger Guard Rear
18		Fixed Screw	36		Washer

SPARE PART DIAGRAM

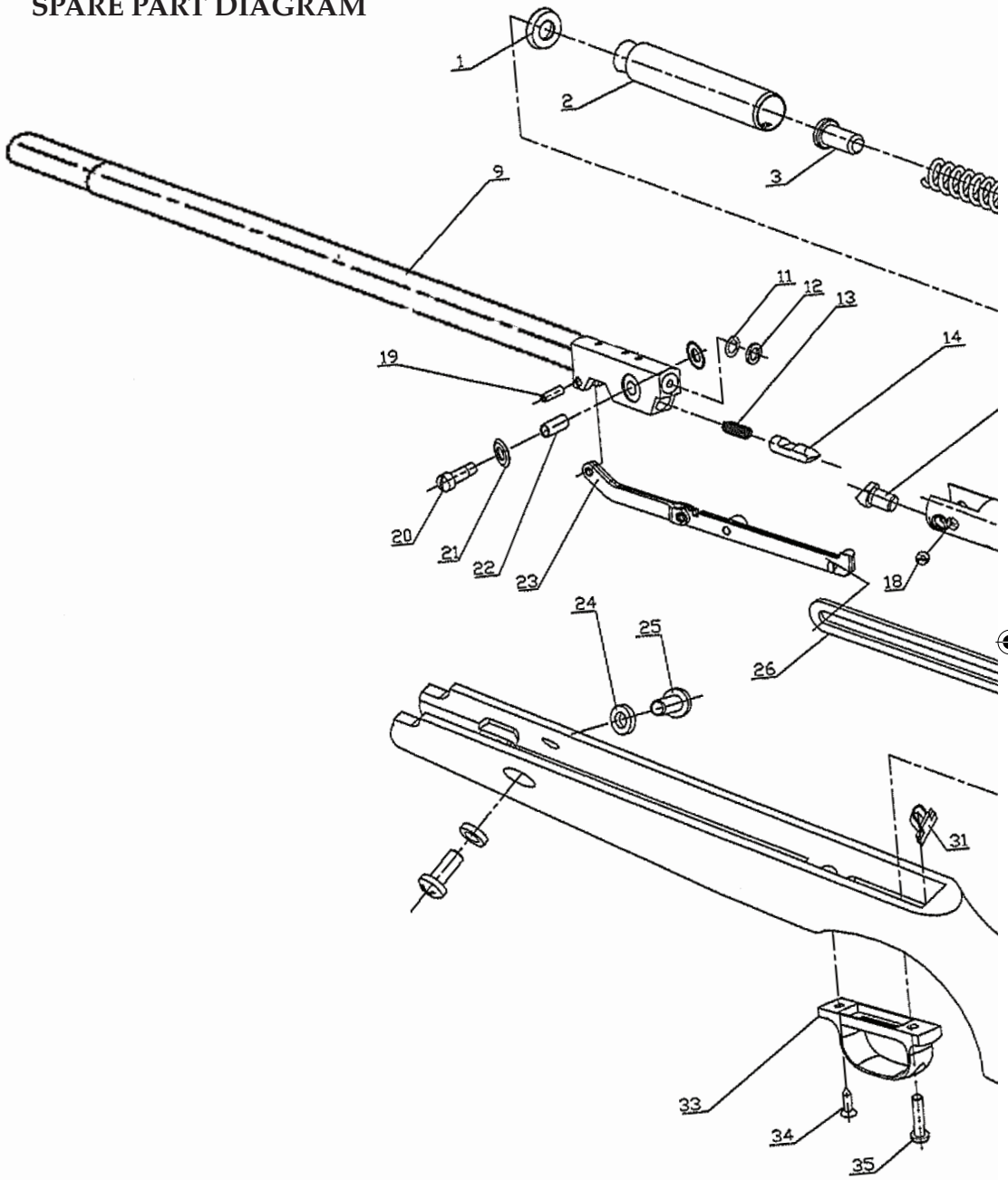

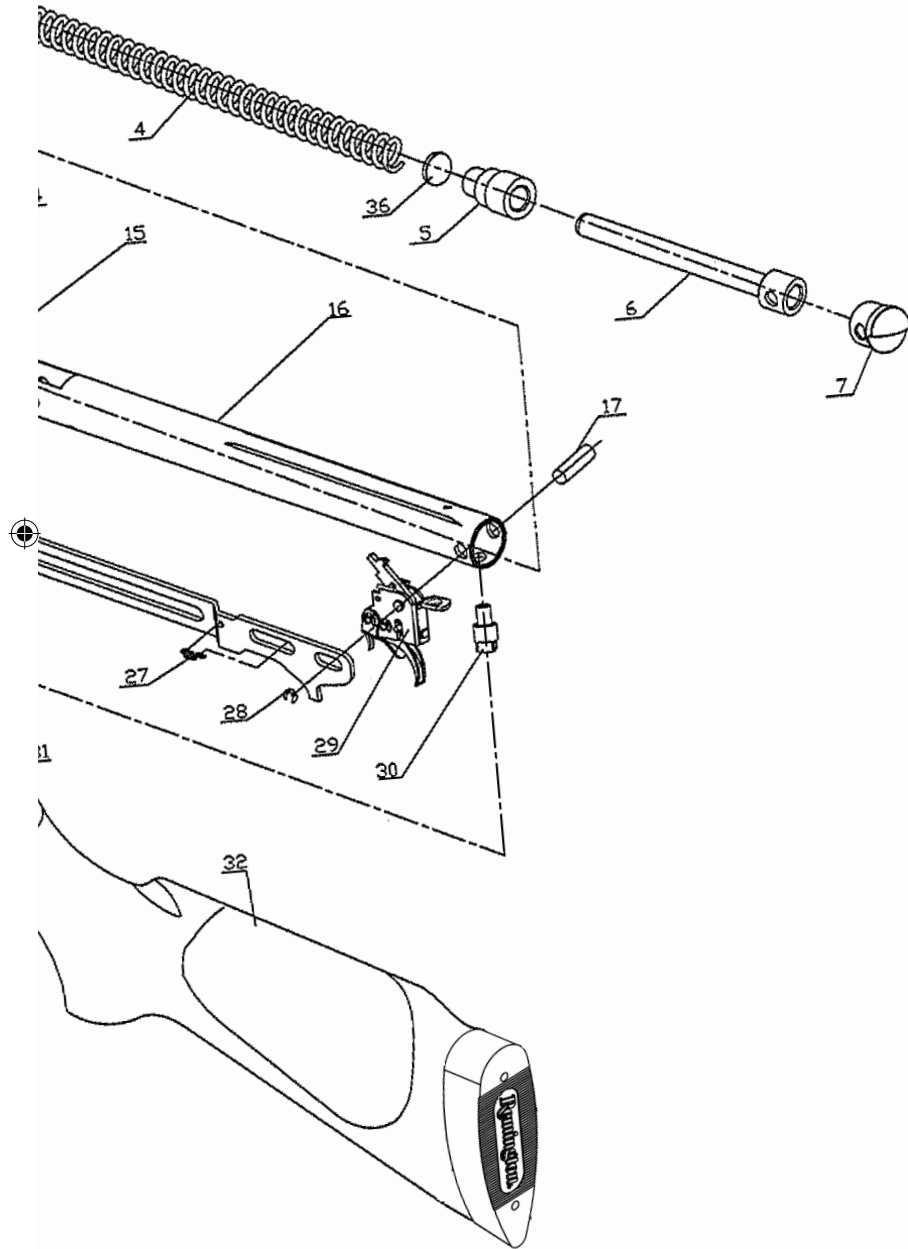

SPECIAL TERMINOLOGY

ENGLISH

Horizontal Sight Adjustment
Vertical Sight Adjustment
Joint washer
Loading Lever
Fixing Screw
Barrel Fixing Plunger

AMERICAN

Windage Adjustment
Elevation Adjustment
Breech Seal
Cocking Arm
Lock Screw
Detent



ONE YEAR WARRANTY FOR AIR RIFLE

Remington Arms Company, LLC (“RAC”) warrants to the original purchaser (“OP”) of a new air rifle from RAC that such air rifle shall be free from defects in material and workmanship for one year from the date of original purchase by the OP. RAC, in its sole discretion, shall repair or replace the air rifle if the OP, subject to the instructions in this warranty, submits a claim to remedy a defect in the material or workmanship of the air rifle. If RAC opts to replace the air rifle, RAC will keep the air rifle that it replaces. The OP’s remedies under this warranty are limited to repair or replacement of the air rifle; RAC will not provide cash, credit, or refund. RAC does not warrant against any type of defect to the air rifle that RAC did not cause, including but not limited to:

1. Failure to provide proper care and maintenance,
2. Accidents, abuse or misuse,
3. Barrel obstruction,
4. Improper ammunition,
5. Unauthorized adjustments, repairs or modifications, or
6. Normal wear and tear.

Additionally, RAC EXCLUDES AND WILL NOT PAY INCIDENTAL OR CONSEQUENTIAL DAMAGES UNDER THIS WARRANTY. INCIDENTAL OR CONSEQUENTIAL DAMAGE MEANS ANY LOSS, EXPENSE, OR OTHER DAMAGE THAT CANNOT BE REMEDIED BY EITHER REPAIRING ANY DEFECT IN THE AIR RIFLE OR BY REPLACING THE AIR RIFLE. RAC EXPRESSLY EXCLUDES IMPLIED WARRANTIES; THERE ARE NO WARRANTIES WHICH EXTEND BEYOND THE DESCRIPTION ON THE FACE HEREOF THAT RELATE TO MERCHANTABILITY, FITNESS, OR OTHERWISE. Furthermore, no individual or entity other than RAC possesses the authority to alter the obligations, limitations, disclaimers, or exclusions under this warranty or any other RAC warranty. The OP, in order to achieve eligibility under this warranty, must complete and submit the warranty registration card within thirty (30) days of purchase. The OP, upon discovering a defect in material or workmanship in the air rifle, shall contact RAC at:

Remington Arms Company, LLC
870 Remington Drive, P.O BOX 700, Madison, North Carolina 27025.
Telephone: 1-800-243-9700
Fax: 336-548-7801

RAC, upon receiving the OP’s correspondence or phone call, shall provide instructions to the OP governing the manner in which to return the air rifle for repair or replacement. The OP must submit a copy of its sales receipt for the air rifle when returning the air rifle. In the unlikely event that this Remington® Tyrant™ Break Barrel Air rifle needs to be returned to Remington® for service/ repair, the owner must prepay freight. We will not accept COD shipments. Remington® does not accept responsibility for any damage or delay occurring during transit.

THIS IS THE WARRANTY CERTIFICATE

This rifle has a one year unlimited warranty against all production defects. However the warranty will become void if used inappropriately, has been modified or dismantled. In the unlikely event your air rifle should develop a fault the first action should be to contact your Airgun retailer. In the unlikely event that this Remington Tyrant™ Break Barrel Air rifle needs to be returned to Remington for service / repair, the owner must prepay freight. We will not accept COD shipments. Remington does not accept responsibility for any damage or delay occurring during transit.

PLEASE RETURN THIS WARRANTY CARD TO:

Remington Arms Company, LLC
870 Remington Drive, P.O BOX 700, Madison, North Carolina 27025.
Telephone: 1-800-243-9700
Fax: 336-548-7801

NAME :

DATE OF BIRTH :

ADDRESS :

TELEPHONE :

EMAIL ADDRESS :

MODEL :

CALIBER :

SERIAL NUMBER :

DATE OF PURCHASE :

STAMP OF YOUR RETAILER / COPY OF THE RECEIPT

[Empty rectangular box for retailer stamp or receipt copy]





Be a Safe Shooter!

**Read and understand this manual
before operating your airgun!**

Safety is Your Responsibility!



WARNING! This airgun is classified as an adult gun and is recommended for adult use only. This airgun is exempt from specific types of trigger pull, safety mechanisms and drop test requirements. This airgun may discharge if dropped. Misuse or careless handling of the airgun may result in property damage, personal injury and/or death.

Remington[®]

Remington Arms Company, LLC
870 Remington Drive, P.O. Box 700, Madison, NC 27025-0700
www.remington.com